

32ETS MODEL SPECIFICATIONS

APPLICATIONS: OPEN
CEILINGS/WAREHOUSE

DOME ASSEMBLY: DOME SEALED WITH HIGH PERFORMANCE SEALANT AND LOCKED ONTO AN ALUMINUM RING TO ELIMINATE ANY STRESS AND INCREASE LONG TERM DURABILITY. UNIQUE DESIGN TO ALLOW ANY CONDENSATION BUILD-UP TO ESCAPE BY SITTING OUTSIDE THE FLASHING.

MATERIAL: 100% HIGH-IMPACT ACRYLIC WITH UV STABILIZERS, .220" (5.588MM) THICKNESS PRIOR TO FORMING, CC2 LIGHT-TRANSMISSION PLASTIC MATERIAL, NON-YELLOWING. 1100-O ALUMINUM DOME RING, .080" (2.032MM) THICKNESS. OSHA FALL PROTECTION CERTIFIED.

SCATTER DISK: DESIGNED TO HELP DISTRIBUTE LIGHT EVENLY THROUGHOUT ROOM BELOW BY SCATTERING LIGHT RAYS INTO THE LIGHT TUBE, ELIMINATING SHARP SUN RAYS AND RAINBOW EFFECT. ALSO CAPTURES SUNLIGHT FROM LOW ANGLES INTO THE LIGHT TUBE.

MATERIAL: 100% HIGH-IMPACT PRISMATIC ACRYLIC WITH UV STABILIZERS, .125" (3.175MM) THICKNESS PRIOR TO FORMING, CC2 LIGHT-TRANSMISSION PLASTIC MATERIAL, NON-YELLOWING.

DUST SEAL: DESIGNED TO PREVENT BUG, DIRT, AND AIR-INFILTRATION IN THREE BREATHABLE LOCATIONS OF THE TUBULAR SKYLIGHT.

MATERIAL: POLYPROPYLENE WEATHERSTRIP PILE WITH 3M ADHESIVE BACKING.

ROOF FLASHING: ENGINEERED ONE-PIECE SEAMLESS FLASHING WITH 4" (101.600MM) WIDE BASE FLANGE TO SECURE AGAINST ANY LEAKS AND INCREASE LONG TERM DURABILITY.

MATERIAL: 1100-O ALUMINUM

OPTIONS:

FLAT - 9"(228.600MM) HEIGHT, .125" (3.175MM) THICKNESS.

CURB CAP - FOR WOOD OR METAL BUILT-UP CURBS. 38.625" X 38.625 (981.075MM x 981.075MM), .080" (2.032MM) THICKNESS.

LIGHT TUBE/ELBOW: 98% REFLECTIVE ANODIZED ALUMINUM LIGHT TUBES AVAILABLE IN 24" (609.600MM) RIGID LENGTHS, AND ALSO ADJUSTABLE ELBOWS AVAILABLE IN 12" (304.800MM) SECTIONS.

MATERIAL: .020" (0.508MM) THICKNESS ANODIZED FINISH ALUMINUM, 25 YEAR MANUFACTURE WARRANTY AGAINST CRACKING, PEELING OR YELLOWING.

INDUSTRIAL TRIM RING ASSEMBLY: A UNIQUE ONE-PIECE BRUSHED ALUMINUM RING SEALED WITH A DUAL DIFFUSER, FASTENS DIRECTLY TO LIGHT TUBE FOR OPEN CEILING APPLICATIONS.

MATERIAL: IMPACT RESISTANT POLYCARBONATE, WITH UV STABILIZERS, CC1 LIGHT-TRANSMISSION PLASTIC MATERIAL, NON-YELLOWING, 1100-O ALUMINUM TRIM RING, .080" (2.032MM) THICKNESS.

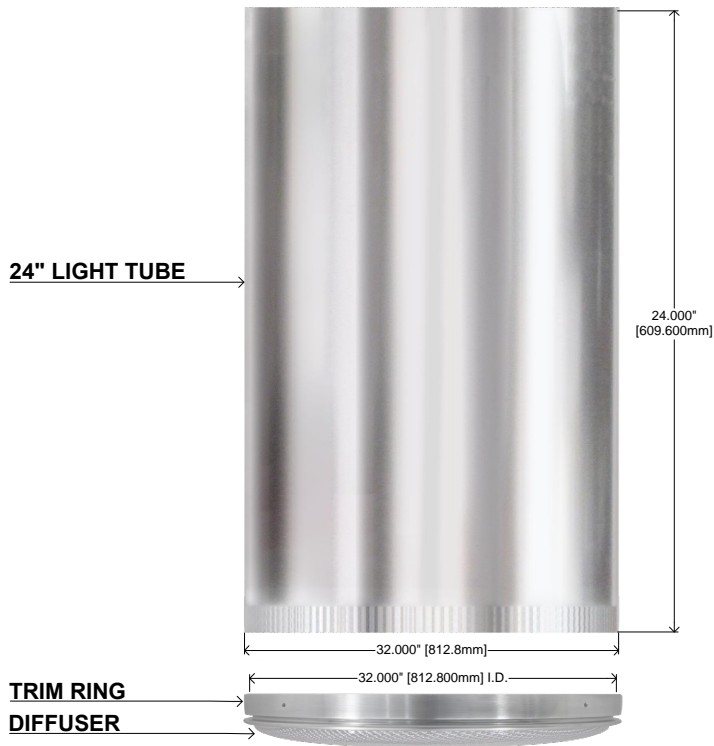
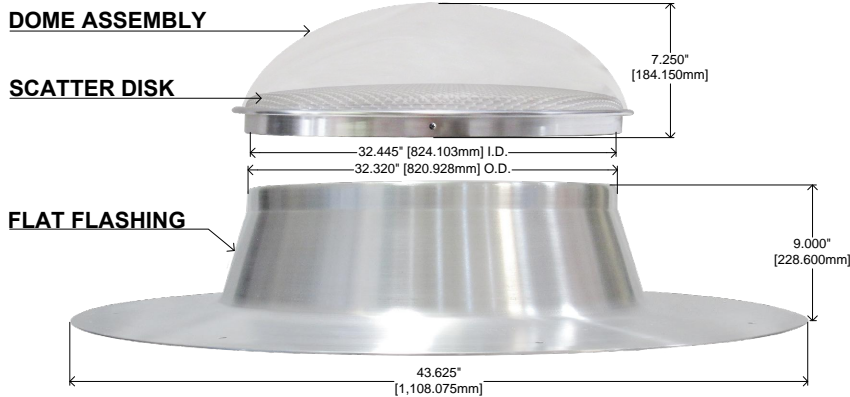

APPROXIMATE COVERAGE AREA	APPROXIMATE LIGHT OUTPUT (LUMENS) WILL VARY WITH CEILING HEIGHT	EQUIVALENT OPTICAL POWER (WATTS)
1,000 FT ²	UP TO 21700	APPROX. 1,800

TIME OF DAY, SEASON, LENGTH OF TUBE AND ELBOWS WILL VARY LIGHT OUTPUT

FLASHING OPTIONS

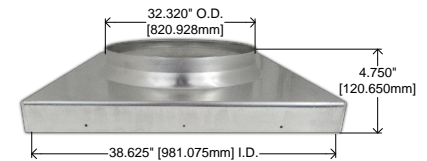

CURB FLASHING

ALL ETS COMPONENTS MANUFACTURED IN CHANDLER, AZ SINCE 2001



FLORIDA BUILDING CODE
FL21444



DO NOT SCALE DRAWING		0 5 10 25 50	
DESCRIPTION: 32" INDUSTRIAL TUBULAR SKYLIGHT			
PART No: 32ETS		THIS DRAWING AND THE INFORMATION CONTAINED HERE IN IS THE SOLE PROPERTY OF ELITE SOLAR SYSTEMS, INC. ALL IDEAS ARE CLASSIFIED AND CANNOT BE REVEALED TO ANYONE WHO MAY BE CONSIDERED A COMPETITION. UNAUTHORIZED USE OR REPRODUCTION OF ANY PART OF THIS DRAWING IS STRICTLY PROHIBITED.	
DWG No: 32ETS-2019	DATE: 03-2019	REV:	DRAWN BY: J. ESTRADA