

Artistic Skylights conform to and exceed test requirements of the following criteria: AAMA/WDMA/CSA 101/I.S.2/A440-17 (NAFS - North American Fenestration Standard / Specification for windows, doors and skylights)

Skylights are suitable for use on flat roofs only. Designed for mounting on 3"(75mm) or 4"(102mm) curbs with flashing (by others), these units provide excellent performance and flexible design to achieve large daylight openings.

- Custom sizes are available upon request



Model MW-CF-FF-VE Available Sizes			
Model #	Outside Curb Dimensions		Glazing Type
MW-CF-FF-VE - 36	33½" x unlimited	(845mm x unlimited)	
MW-CF-FF-VE - 42	40" x unlimited	(1016mm x unlimited)	
MW-CF-FF-VE - 52	49½" x unlimited	(1251mm x unlimited)	
MW-CF-FF-VE - 60	58" x unlimited	(1473mm x unlimited)	
MW-CF-FF-VE - 72	70" x unlimited	(1778mm x unlimited)	
MW-CF-FF-VE - 80	78" x unlimited	(1981mm x unlimited)	
MW-CF-FF-VE - 96	92½" x unlimited	(2350mm x unlimited)	
MW-CF-FF-VE CUST.			
Glazing Available			
Glazing Type	Colour Code	Glazing Type	Colour Code
Clear	C	White	W
Bronze	B		

Project:
Contractor:
Architect:
Approved By:
Date:

Specifications:

Skylight shall be factory assembled Model No. \_\_\_\_\_ MW-CF-FF-VE as manufactured by Artistic Skylight Domes Ltd. Vaughan, Ontario. Glazing shall consist of 16mm multi-wall polycarbonate panels (optional 25mm) in clear, optional bronze or translucent white. The skylight shall consist of corrosion resistant extruded aluminum curb frame, 6063-T5 alloy, with heliarc welded corner. The skylight curb frame shall have an extruded rigid vinyl thermal break, which incorporates a high capacity, sloped condensation gutter with drainage to exterior, and co-extruded rubber draft seal. The retaining cap frame shall be extruded, mill finish, 6063-T5 aluminum alloy with heliarc welded corners. Mullions shall consist of 3" mill finish, pre-arc'd, extruded aluminum channel and pressure plate of 6063-T5 alloy, with keyed in place Santoprene gaskets and spacers. Channel spacing approximately 4' on centre.

SECTION - A

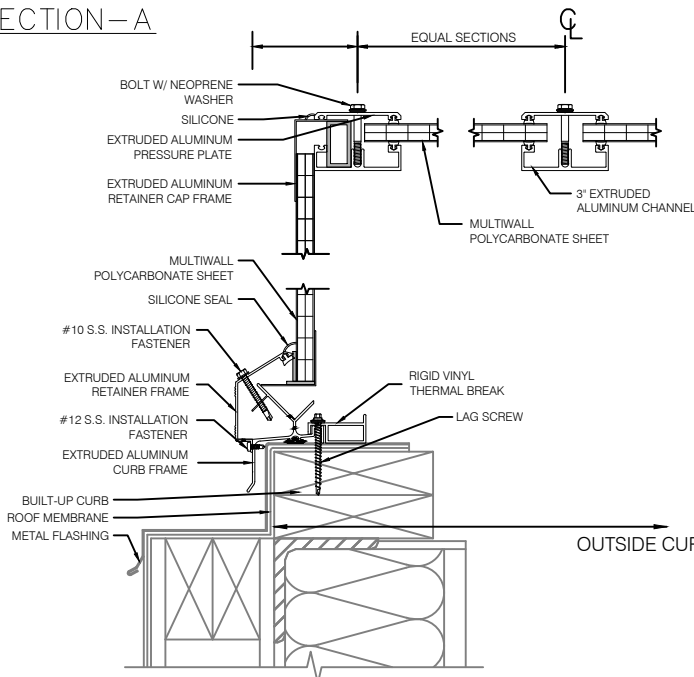

SECTION - B

